



4015B2 feat. the REVOLVER

NEWTEC

15-head weigher

the world leaders

perfectly vertical discharge of products for VFFS packaging

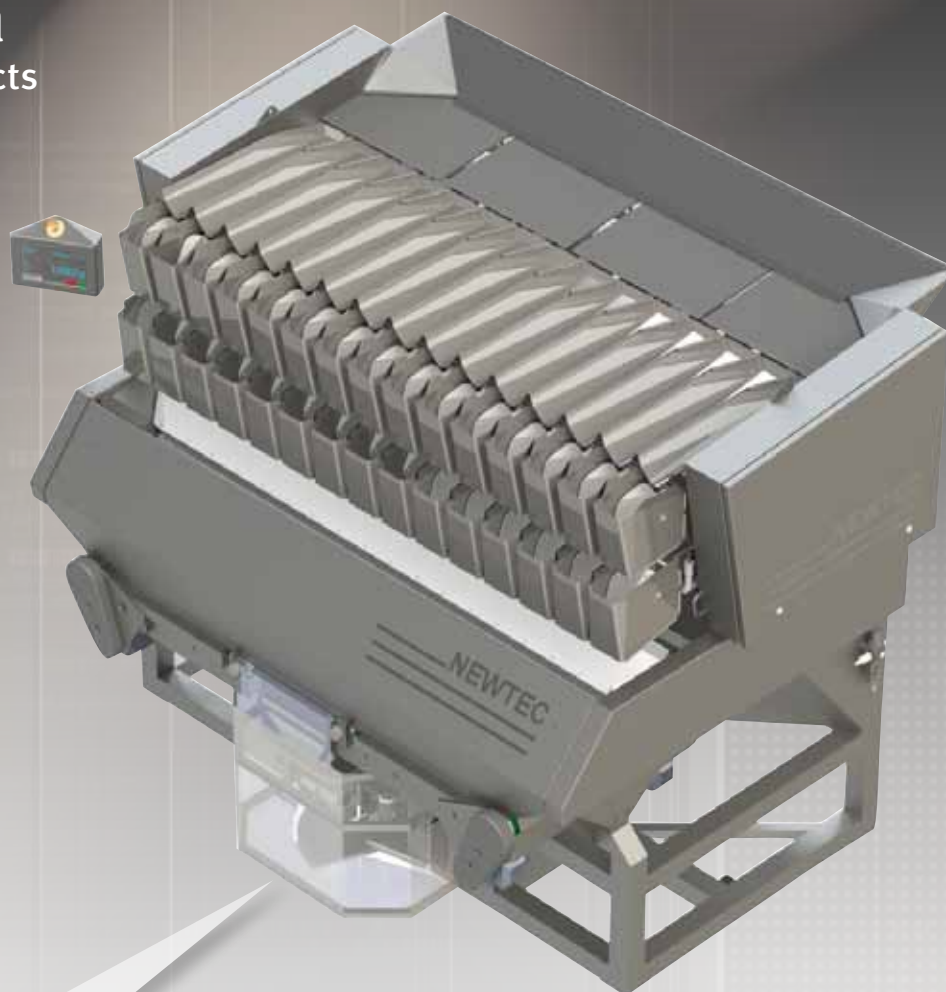

up to **100** portions per minute



- VarioSpeed function to keep pace with infeed unit
- Count-to-target optional kit
- Graphical touchscreen controller with 5m cable for easy reach around the weigher
- NEWTEC WebServices enabled for data collection, archiving and process monitoring
- Fully removeable weigh heads –no tools needed
- Detachable collecting pans in the portion collecting system

The Revolver mechanism

Engineered by NEWTEC, it discharges portions continuously and brings speed and accuracy.

NEWTEC

the world leaders

4015B2 REVOLVER with optional "Count-to-target"

The count-to-target kit provides **optical** counting ensuring you meet demand for packs containing any **certain number** of products. It consists of a sensor bar and brusher mounted additionally on the weigher.

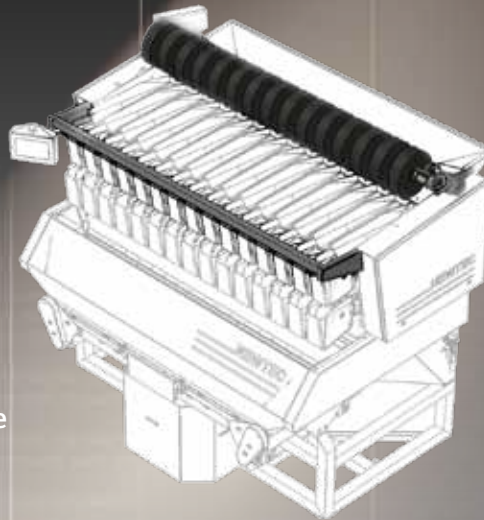

Count-to-target Kit

Portions delivered per min (single discharge)

Produce/Pack	0.5kg	1kg	2.5kg	5kg**
Potatoes or onions*	up to 100	up to 95	up to 85	up to 40

*Product size range: Ø 20mm- 80mm; Length 20mm-100mm. **5kg portions require 2x discharges. Actual numbers of portions delivered/min are subject to product size.

NEWTEC A/S
Staermosegaardsvej 18
DK-5230 Odense M
Denmark

T: +45 66 15 84 44
F: +45 66 15 44 39

sales@newtec.com
www.newtec.com

Technical Data

Weight:	1010kg
Width:	2610mm
Height:	2071mm
Length:	1877mm
Air:	Connection 3/8" Pressure 0.6Mpa / 6 Bar Consumption 300NI/min
Electrical:	230/400 VAC(N)PE 3.5kW
Environmental Conditions:	5°C - 40°C / 41°F - 104°F
Protection Class:	IP 54

Built in accordance with the Measuring Instruments Directive (MID)



Newtec Standard Features

- Stainless steel structure
- Easy-to-use interface (**consistent throughout our weighers**)
- Graphical touchscreen
- WebServices enabled

Dealer's stamp / Notes

