

PL Peeler series

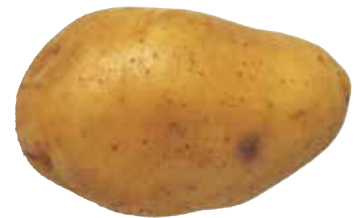

Heavy duty peelers
designed and constructed for the food processing
industry



PL Peeler series: PL 25S, PL 25K, PL 40K



for peeling
potatoes, carrots,
beetroot, turnips
and other
root vegetables

The PL Series has two peeling systems and a washing system to choose from.

- The **knife system** peels the potatoes, carrots, beetroot, turnips and other hard vegetables like hand peeled and therefore is the ideal solution for whole peeled product with longer shelf life. The peeled potatoes do not discolour.
- The **abrasive system** peels quick and price effective for further processing. Aluminium oxide abrasive coat and disc can be replaced through rubber-coated cylinder and disc thus changing the abrasive peeling machine into a root tuber washing machine
- The **rubber knop system** can be used for washing potatoes, carrots, etc. The rounded, easy-to-clean peeling chamber guarantees residue-free waste management that helps ensure a hygienic environment. Washing and peeling in one step: By means of the integrated top-water spraying the products are washed during peeling and the carborundum layer is cleaned.

The PL Peelers are equipped with an adjustable timer from 1 to 6 minutes (PL 25S) and 1 to 10 minutes (PL 25K & PL 40K).

The **pneumatic door opening** (optional for PL 40K) allows trouble-free integration of the machine into automatic production process. Emptying via pneumatic door opening - followed by automatic closing of the door for next peeling.

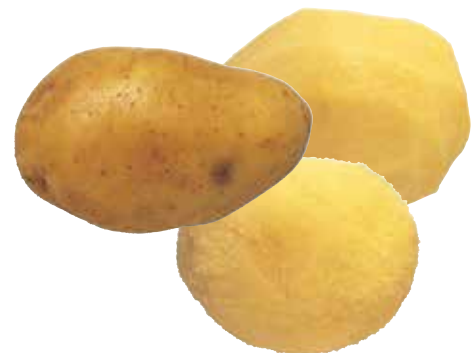

The PL peelers are ideally suited to be integrated in complete and continuous root processing lines for washing, peeling, cutting / dicing up to 1.200 kg per hour. The loading and peeling process is central controlled.

Economical & systematic peeling of root vegetables

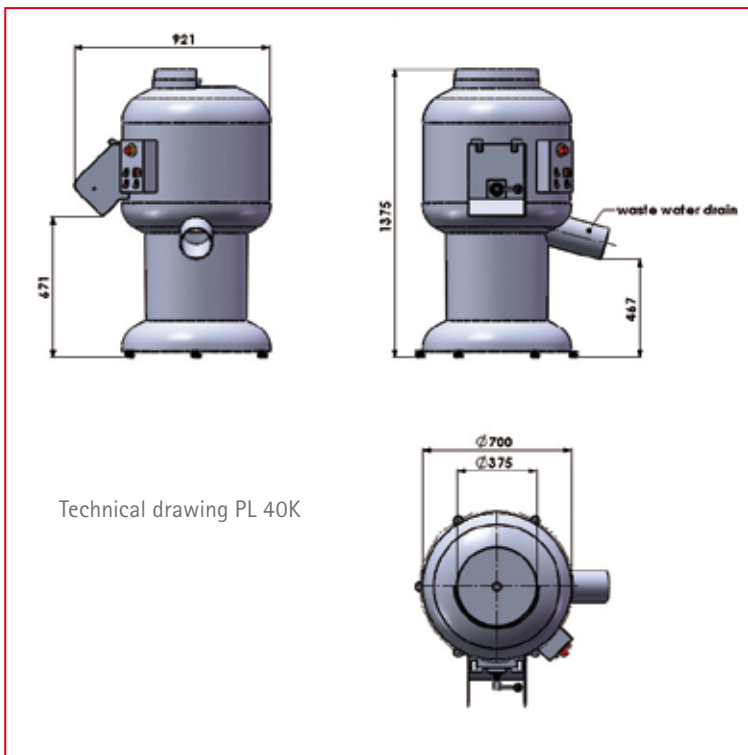

Technical specifications PL 25K:

Processing volume depending on product:	up to 400 kg/h
kg per batch:	25 kg
Voltage	400V, 50H or 220V, 60Hz / 3Ph
Total power:	1,1 kW
Dimensions (WxLxH):	815 x 705 x 1285 mm

Technical specifications PL 25S (Super knife system):

Processing volume depending on product:	up to 400 kg/h
kg per batch:	25 kg
Voltage	400V, 50H or 220V, 60Hz / 3Ph
Total power:	1,5 kW
Dimensions (WxLxH):	735 x 750 x 1195 mm

Technical specifications PL 40K:

Processing volume depending on product:	up to 600 kg/h
kg per batch:	40 kg
Voltage	440V, 50H or 220V, 60Hz / 3Ph
Total power:	1,5 kW
Dimensions (WxLxH):	930 x 921 x 1375 mm



Quick exchange of peeling basket

Peeling basket and peeling disc can be exchanged in less than 3 minutes. This, in combination with the rounded floor of the peeling machine allows an easy and safe cleaning.

The large inner diameter allows gentle peeling and low pressure on the product.



Innovative knife peeling system (PL 25S)

Both sides of the blades are used through right and left rotation. Direction of rotation can be reversed via Cekon adapter. The mechanically processed potatoes are identical in appearance to hand-peeled potatoes. The super smooth surface given after peeling and the fresh look given to even old potatoes is amazing. Waste is minimal. The blades are arranged so that the round or oval shaped potatoes are guided between the blades to the depth of their peel. Stones and other foreign materials are automatically expelled over the backs of the blades.



Various grain sizes for individual customer requests

Many grain sizes are available according to different product requirements and customer requests:

- EK24 for potatoes and other root and tuber vegetables
- Fine or coarse coatings upon request

Product Range:

- **Belt cutting machines**
GS 10-2, GS 20, GS 25V
- **Slice and wedge cutters**
Tona S, Tona E, Tona S 180K
- **Special cutting and punching machines**
Tona Rapid, Tona Rapid 3D, Tona Rapid XL, Multicorer, TT 450, Multislicer
- **Cube and strip cutter** KUJ V
- **Multi purpose cutting machine** KSM 100
- **Cabbage cutting machine** CAP 68
- **Cabbage corer** KSB
- **Dicing, wedging & shaping machine** PGW, HGW
- **Vegetable and salad washing equipment**
- **Peeling machines**
for citrus fruit, melons, apples, pineapples, potatoes, carrots, turnips, beetroot, etc.
- **Centrifuges and air blowing systems**
- **Vertical flow packaging machines**
- **Special machines**
- **Complete production lines**

We develop and manufacture single and special machines as well as complete processing lines for the food processing industry.

We successfully implement production processes for you by effectively combining single machines.

KRONEN - smart solutions and convincing technology for the food processing industry!

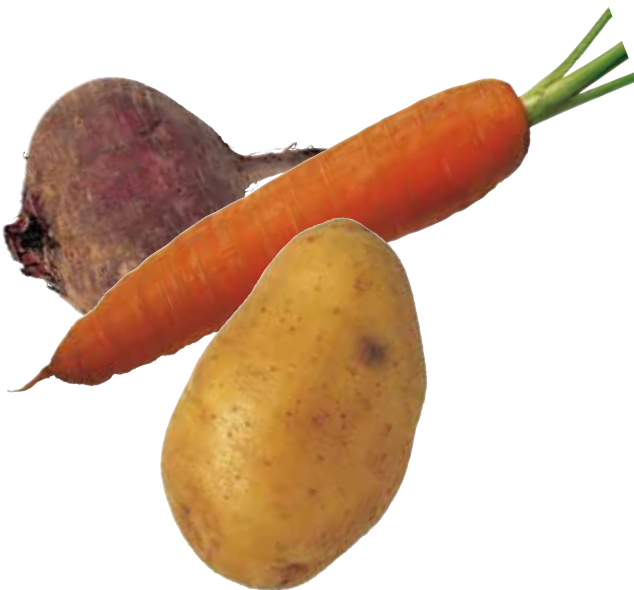

KRONEN GmbH

Römerstraße 2a
D-77964 Kehl am Rhein
Telephone: +49 (0) 7854/96 46-0
Telefax: +49 (0) 7854/96 46-50
info@kronen.eu

www.kronen.eu

An enterprise of
Zillgith Beteiligungs GmbH