



DS-781SS

Waterproof Price Computing Scale

**For Accurate Fast and Friendly
Sales Transactions in Bad Environment**

Washable Stainless Steel Housing (IP68)
High contrast LCD display
Preset keys and 99 PLU
Weighing up to 30kg
Long battery life
Compact and portable



***Searching for
a New Balance***

Washable stainless steel housing makes it simple to ensure that the scale is kept constantly clean and allows you to provide the customer with " safe and secure " commodity.

Weighing capacity up to 30kg

Auto power off function

Fast weighing speed

Portable and easy to carry design

Preset keys to call up unit price or PLU for fast transactions



Customer side display



● **99 PLU can be programmed with unit price and tare weight**

● **4xC size dry battery for more than 600 hours continues operation**

Dimensions

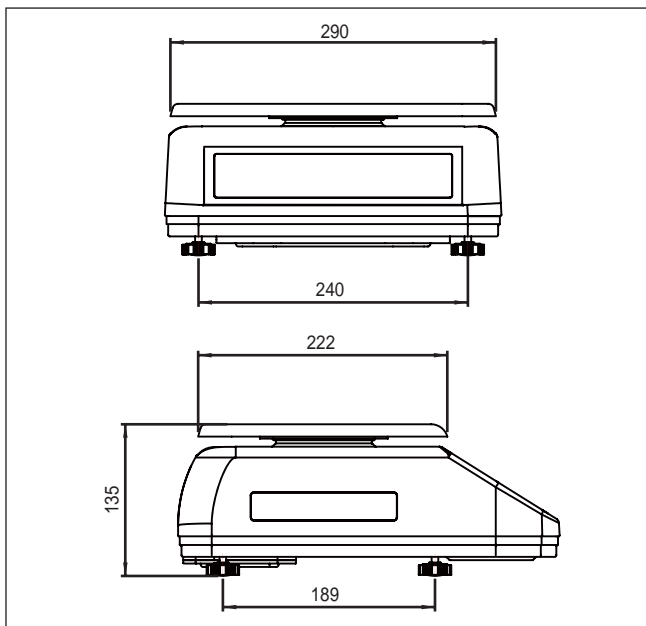

Specifications

Capacity and scale interval	3/6kg 1/2g	6/15kg 2/5g	15/30kg 5/10g
-----------------------------	---------------	----------------	------------------

- Display ----- Weight: 5 digits
Unit price: 5 digits
Total price: 6 digits
- Power Source ----- AC: Adapter(DC 5V ~ 8V, 100mA)
DC: 4 x C size dry battery
- Power Consumption ----- 0.12W when using dry battery
0.24W when DC 6V
- Operating Temperature -- -10 ~ +40
- Operating Humidity ----- 15 ~ 85%RH
- Platter Size ----- 290 x 222mm
- Dimensions ----- 300(W) x 340(D) x 135(H)mm

*Specifications are subject to change without prior notice.

TERAOKA SEIKO CO., LTD.

13-12 Kugahara 5-chome, Ohta-ku,
Tokyo 146-8580, JAPAN
TEL: +81-3-3752-2131
FAX: +81-3-3752-2801
URL: <http://www.digisystem.com>
E-MAIL: info@hq.digi.co.jp

TERAOKA WEIGH-SYSTEM PTE LTD.

4, Leng Kee Road, #06-01, SIS Building,
SINGAPORE 159088
TEL: +65-6861-3911
FAX: +65-6861-3144

SHANGHAI TERAOKA ELECTRONIC CO., LTD.

TINGLIN INDUSTRY DEVELOPMENTAL ZONE,
JINSHAN COUNTY, SHANGHAI 201505
TEL: +86-21-57234888
FAX: +86-21-57233049
<http://www.digisystem.com>