

External Dimensions (mm)

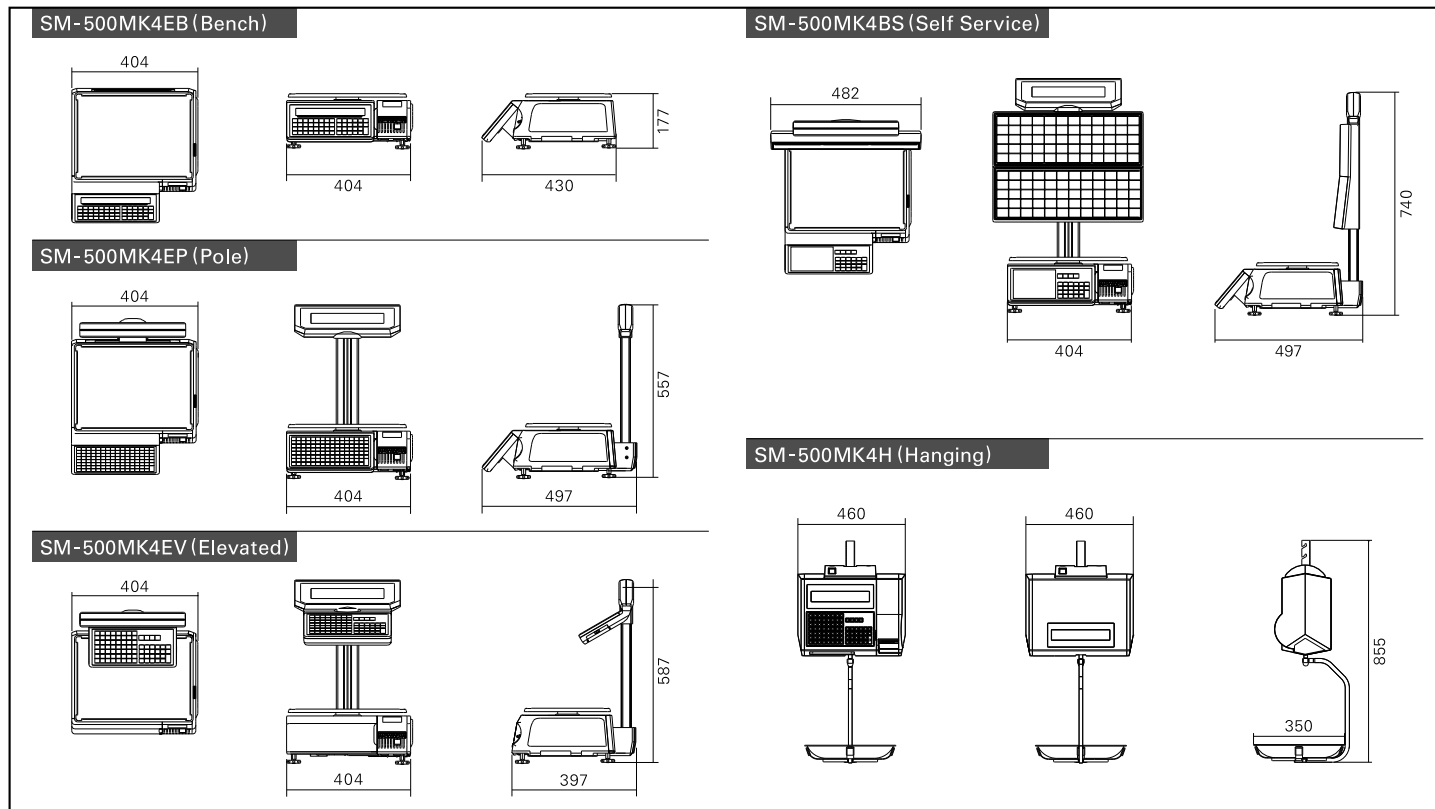

Specifications

Capacity	Max 6kg	Max 15kg / 30lb	Max 30kg
Single Interval	e = 2g 1/3,000	e = 5g / 0.01lb 1/6,000 or 1/7,500	e = 10g 1/6,000 or 1/7,500
Capacity	Max 3 / 6kg	Max 6 / 15kg	Max 15 / 30kg
Multi Interval	e = 1 / 2g	e = 2 / 5g	e = 5 / 10g

Model	SM-500MK4EB (Bench)	SM-500MK4EP (Pole)	SM-500MK4EV (Elevated)	SM-500MK4H (Hanging)	SM-500MK4BS (Self Service)
Display	LCD with Backlight (16 x 134 Dots)				
Number of Preset Keys	32	56 or 100	56 or 100	56	48, 60, 96 or 120
Memory Capacity	2MB (Std), 10MB (Max)				
Display Resolution	1/3,000, 1/6,000, 1/7,500				
Label Size	72mm x 240mm (Max)				
Label / Receipt Roll Diameter	105mm				
Paper Width	Label: 80mm Receipt: 60mm				
Printing Speed	Label: Up To 150mm / Second* Receipt: Up To 150mm / Second*				
Power Source	AC 100 / 110 / 220 / 230 / 240 Volts (50/60 Hz)				
Operating Temperature	-10°C to +40°C				
Humidity	15% to 85% RH				
Standard Interface	RS232C, Ethernet 10/100 Base T, PS2Keyboard, Cash Drawer				
Net Weight	11.30kg	12.90kg	13.80kg	16.30kg	17.10kg

Options Wireless LAN (IEEE 802.11b/g), RS-485 (Factory Preset), Memory Expansion Board (8MB), Linerless Receipt Cassette

* To achieve maximum print speed, high sensitivity thermal paper is necessary. Contact DIGI for details.



• ISO 9001



• Specifications are subject to change without prior notice
• Meet or exceed OIML Class III requirements



SM-500MK4

Scale Printer

Robust, High Throughput System Scale



SM-500MK4EP

TERAOKA WEIGH-SYSTEM PTE LTD.

4 Leng Kee Road #05-02/03/04/05/11
SIS Building SINGAPORE 159088
TEL : +65 6472 2996
SALES: +65 6378 5387
FAX : +65 6863 4614
URL : www.teraoka.com.sg
E-MAIL : bdd@teraoka.com.sg

TERAOKA SEIKO CO., LTD.

13-12 Kugahara 5-chome, Ohta-ku,
Tokyo 146-8580, JAPAN
TEL : +81-3-3752-2131
FAX : +81-3-3752-2801
URL : www.digisystem.com
E-MAIL : info@hq.digi.co.jp

SM500MK4 / G / 0313

Searching for
a New Balance

Scale to New Heights with the Powerful Features of SM-500MK4



SM-500MK4 Variations

Fast Processing & Printing Speed

Significantly improve the weigh-to-print time with SM-500MK4's faster processor and printing speeds to increase throughput and operation efficiency, especially during busy times.

High Memory Capacity

With standard memory of 2MB that can store up to 10,000 PLUs and upgradeable to a maximum of 10MB, the SM-500MK4 meets current demand for increased label information and also caters to your future needs for additional nutritional facts, ingredients or images.

Ease of Operation

The spacious printer compartment, thermal print head gap space and simple label / receipt cassette allow easy and fast label or receipt changes. Even new operators can replace label / receipt rolls quickly with the optional standby cassette, a very useful tool during peak hours.

Linerless Printing Capability

With linerless printing option, the SM-500MK4 enjoys the benefits of reduced label roll changes, less down time & increased productivity. There is the flexibility to print labels of varying lengths one after another, reducing label wastage and saving money.

Wide Printing Capability

Useful information labels with ingredients, nutritional information and traceability data are easily possible with the wider print width and flexible label format.

Take advantage of the 80mm printing width to print the same content on a shorter label, which translates to faster printing and increased print count within the thermal print head's life span.



80mm Width



60mm Width

Floating Clerk System

Sales transactions of a customer can be captured at various scales when being served by the same clerk within the floating clerk network, printing a total receipt at the end of multiple transactions.

Security Features

To safeguard against unauthorized scale manipulation, security features include:

- Audit Trail
- Date & Time Stamp
- Price Override Lock
- Password Protection
- Wireless Network Security (WPA / WEP / LEAP)

Diagnostic Functions

Remote diagnostic capabilities include monitoring of scale status and firmware upgrade capability to save time and money by reducing on site maintenance.

Networking

The SM-500MK4 supports the following network interfaces:

- RS-232C
- RS-485 (Optional)
- Ethernet 10 / 100 Base T (TCP/IP)
- Wireless LAN IEEE.802.11b/g (Optional)



Scale Application Software

PLU data programming, preset key assignment, label format editor and user security can easily be done from a centralized location.

