

Onion peeler USM-S60



Operating principle

The Sormac onion peeler USM-S60 is equipped with a small storage bin in which the unpeeled onions are placed.

The operator takes the onions out of this hopper and puts them one by one in the right horizontal position in the conveying section. From this point the onions are transported for further processing. The rotating knives top and tail the onions and the cutting arms make a horizontal cut around the onions. At the end of the conveying section the onions are picked up with a double holding-arm system with rotating holders. This arm is fitted on a rotating structure. During the rotating movement the onion spins around its own axis, whereby a cut over the complete circumference is made. The depth of the cut is adjustable. During the cutting air is blown into the cut to remove the skin.

For adapting the machine to different onion diameters several adjustments are provided. These can mostly be made from outside, even during operation, by means of a hand wheel.

The capacity of the machine is 60 onions per minute. By means of the frequency

converter the speed can be easily reduced.

Capacity

Depending on diameter, shape and quality the USM-S60 onion peeler can handle maximal 3.600 onions per hour.

Features

- > competitive price / performance relation
- > perfect peeling quality
- > complete dry peeling
- > low noise level
- > high yield (little waste)
- > hygienic design (easy to clean and disinfect)
- > low energy- and air consumption

Options

- > transport chains for different onion diameters (40 - 60 mm or 80 - 140 mm) (1,57" - 2,36" or 3,15" - 5,5")
- > direct mounted inspection table
- > hopper with elevator belt
- > waste auger

Product specification

The USM-S60 can peel onions with a diameter of 55 - 120 mm. For smaller and larger diameters adjusted executions can be supplied (see options).

Technical data

Voltage:	230/400 V, 3 phase, 50/60 Hz
Total installed power:	2.3 kW
Noise level:	< 84 dB(A)*
Air pressure:	6 bar (dry air) (87 psi)
Air consumption:	approx. 1,2 Nm ³ /min. (42 cfm)
Weight:	700 kg (1,540 lbs)
Dimensions (LxWxH):	3.800 x 1.125 x 2.110 mm (138" x 45" x 79")

*if provided with closed waste auger underneath the machine.

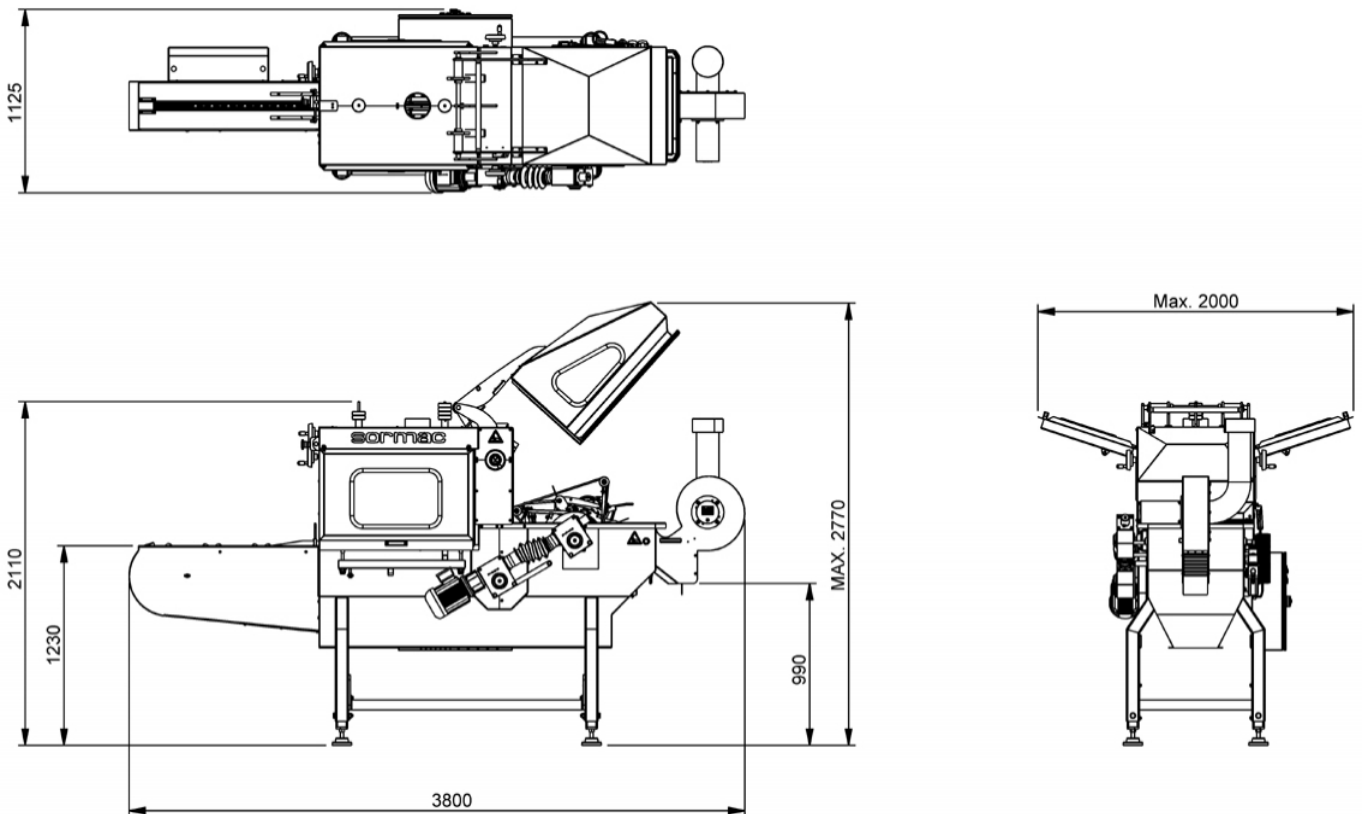
**Sormac B.V.**

P.O. Box 419
NL-5900 AK Venlo

Telephone: +31 (0)77 351 84 44
Fax: +31 (0)77 320 48 01

Huiskensstraat 68
NL-5916 PN Venlo

E-mail: info@sormac.nl
Internet: www.sormac.nl

Alterations reserved