

Centrifuges K50 S & K50 ECO



Spin drying of
of lettuce, vegetable, herbs, fruit
and many more



Centrifuges K50 S & K50 ECO

K50-100S



For spin drying
lettuce, vegetables, fruit, herbs
and many more products !

The K50-centrifuges are used worldwide in the salad, vegetable and delicatessen industry. The KRONEN centrifuges are perfectly suited for spin drying e.g. vegetables such as leek, pepper, carrots, cucumbers, onions, mushrooms, pineapple, etc.

Crunchy lettuce, chicory, Iceberg or lamb's lettuce, delicate herbs are gently dried.

In the delicatessen industry, the dripping-off times of canned products as e.g. crabs, tuna or mushrooms are reduced considerably.

Centrifuge K50-100 S

The TOP-seller of KRONEN centrifuges for vegetables and salads, field-tested and in action hundredfold world-wide.

Convenient handling due to lower infeed height as well as 100 freely programmable memories for the setting of individual spinning speed and spinning time assure optimal adjustment to the produce. A mode with spinning in both directions during the program is also available.



K50-7S

Centrifuge K50-7S

The K50-7S centrifuge is equipped with an inclined cover for a lower infeed height and 7 settings of individual spinning speed and spinning time.



K50-7 ECO

Centrifuge K50-7 ECO

The K50-7 ECO centrifuge offers 7 settings of individual spinning speeds and freely adjustable spinning time, assuring an optimal adaptation to the produce going together with an excellent price value ratio.



K50 ECO-600 & K50 ECO-900

Centrifuge K50 ECO-600 & K50 ECO-900

Fixed spinning speeds (600 oder 900 r/min) and spinning times guarantee constant results for consistent product quality, assuring an optimal price value ratio.

Our standard – the benefits:



Low lift-height for the basket

Compared to the ECO-version, the lift-height of the basket of the K50-S centrifuges is lower by around 30 cm, reducing the lifting and loading through the operator.



Lid lock increases durability

The lid lock, included in all supplies of the S-series, is available as an option for the ECO-series. The lid lock avoids the accidental opening of the lid during centrifuging and unnecessary braking of the motor which prevents damage to motor, brakes and bearing and thus increases the durability of the centrifuge.



Open construction facilitates cleaning

The open, hygienic construction, completely made of stainless steel, guarantees a fast and thorough cleaning. The powerful but low-noised motor assures marginal wear and high durability.



FDA approved

All parts that are in contact with food are made of stainless steel or FDA approved plastic, i.e. all of the machine is FDA approved. FDA approval is documented in manual supplied with machine.

Options and accessories at a glance



Basket slide

Like the basket carousel, the basket slide is also a useful and efficient link between centrifuge and washing machine, assuring a continuous working process and simplifying the change of baskets. The basket slide is available in a straight and an angled version.

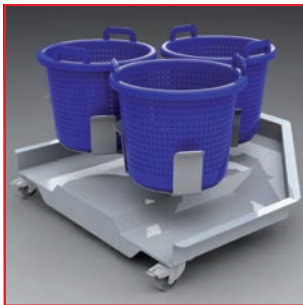

Basket carousel as efficient link

The basket carousel is an efficient link between the KRONEN-centrifuge and the KRONEN-washing machines series GEWA.

The basket carousel guarantees a continuous working process, simplifies the change of baskets and collects any possible product overflow in the stainless steel container.



Easy-to-handle plastic baskets for transport/drying

The plastic baskets (stackable) are light and handy - they are filled with the washed produce and inserted into the centrifuge for spin-drying.



Net insert for fine products

By means of a net insert, available as an option, also sensible products as herbs and seeds can be centrifuged without any problems.

The fine blue nylon filter retains also very small product in the basket.



Technical specifications

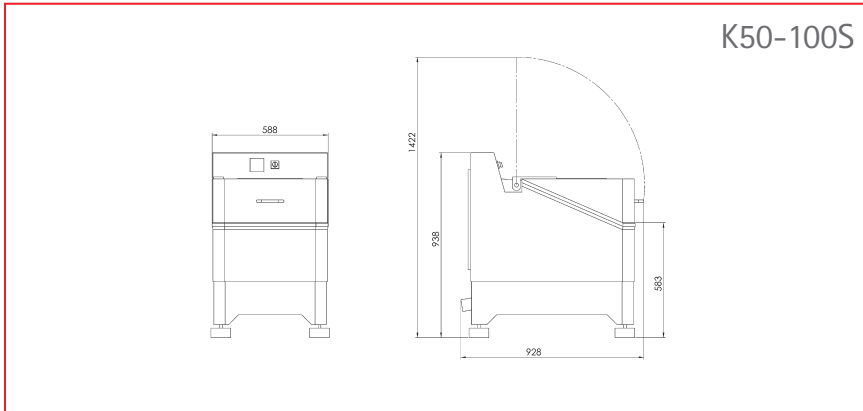

K50-100S

speed	250 - 850 r/min
basket volume	44 l
length	928 mm
width	588 mm
height	938 mm
weight	170 kg
infeed / feeding height	583 mm
discharge / outfeed height	583 mm
total power	0.75 kW
voltage	1~230 V N/PE
frequency	50 Hz
spin time	free adjustable

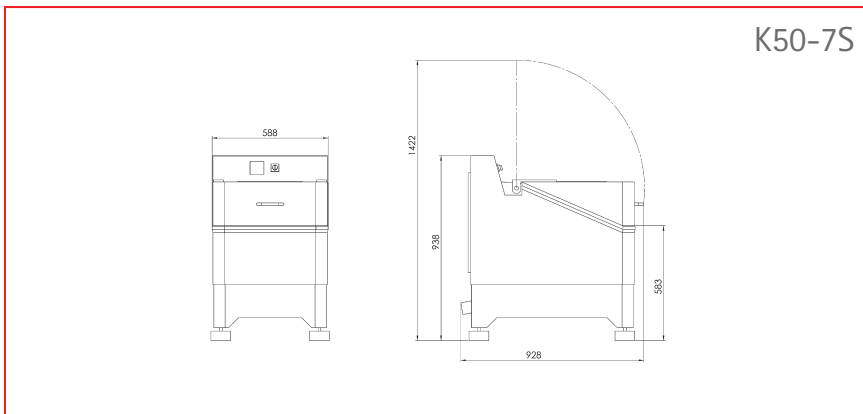

K50-7S

speed	250 - 850 r/min
basket volume	44 l
length	928 mm
width	588 mm
height	938 mm
weight	170 kg
infeed / feeding height	583 mm
discharge / outfeed height	583 mm
total power	0.75 kW
voltage	1~230 V N/PE
frequency	50 Hz
spin time	free adjustable

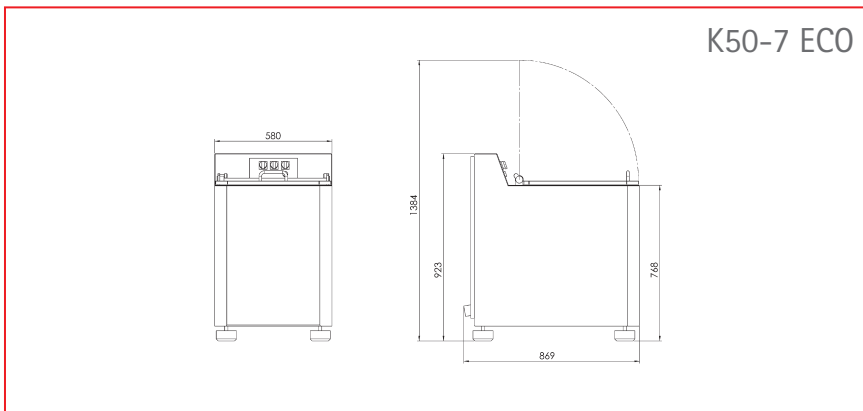

K50-7 ECO

speed	250 - 850 r/min
basket volume	44 l
length	869 mm
width	580 mm
height	923 mm
weight	140 kg
infeed / feeding height	768 mm
discharge / outfeed height	768 mm
total power	0.75 kW
voltage	1~230 V N/PE
frequency	50 Hz
spin time	free adjustable

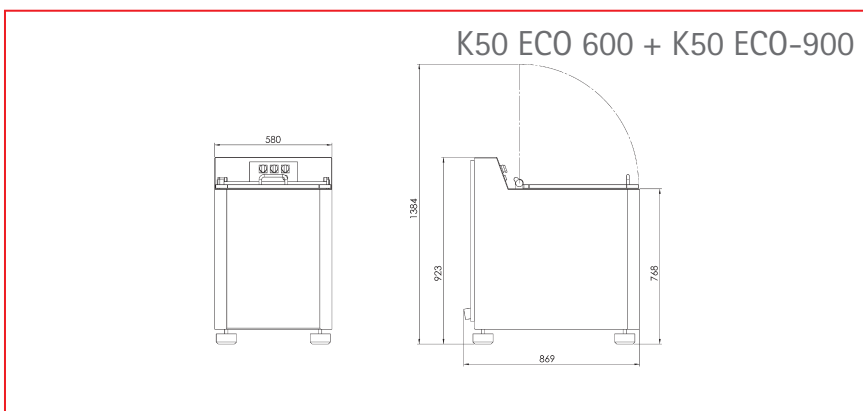

K50 ECO 600 + K50 ECO-900

speed	600 or 900 r/min
basket volume	44 l
length	869 mm
width	580 mm
height	923 mm
weight	140 kg
infeed / feeding height	768 mm
discharge / outfeed height	768 mm
total power	0.75 kW
voltage	3~400 V N/PE
frequency	50 Hz
spin time	fixed

Product Range:

- **Belt cutting machines**
GS 10, GS 20, GS 25, GS 25V
- **Slice and wedge cutters**
Tona S180K, Tona S, Tona E
- **Special cutting and punching machines**
Tona Rapid, Tona Rapid 3D, Tona Rapid XL, Multicorer, Multislicer, TT 450
- **Cube and strip cutter** KUJ
- **Multi purpose cutting machine** SN 100
- **Cabbage cutting machine** CAP 68
- **Cabbage corer** KSB
- **Dicing, wedging & shaping machine** PGW, HGW
- **Vegetable and salad washing equipment**
- **Peeling machines**
for citrus fruit, melons, apples, potatoes carrots, celery, etc.
- **Centrifuges**
- **Packaging machines**
- **Special machines**
- **Complete production lines**



We develop and manufacture single and special machines as well as complete processing lines for the food processing industry.

We successfully implement production processes for you by effectively combining single machines.

KRONEN - smart solutions and convincing technology for the food processing industry!



KRONEN GmbH

Römerstraße 2a
77694 Kehl am Rhein / Germany
Phone: +49 (0) 7854/96 46-0
Fax: +49 (0) 7854/96 46-50
info@kronen.eu