

ReeTray 25 VGT-VGM

Semiautomatic Tray Sealer Machine



ReeTray 25

Semiautomatic Tray Sealer Machine



LAY-OUT ReeTray 25 SXT

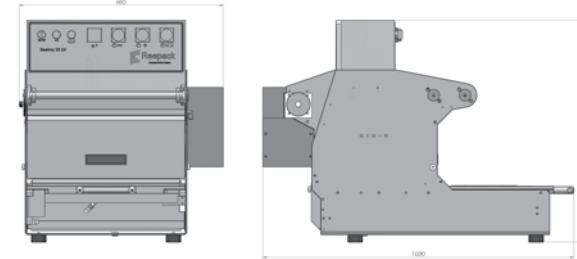

LAY-OUT ReeTray 25 FGT / VGT

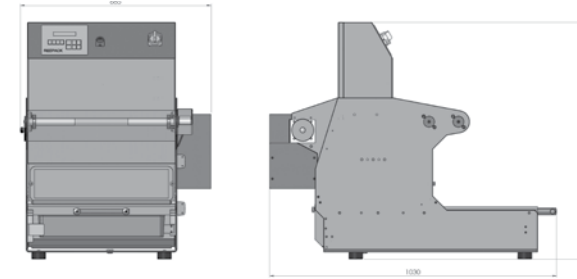

LAY-OUT ReeTray 25 VGM DIGIT

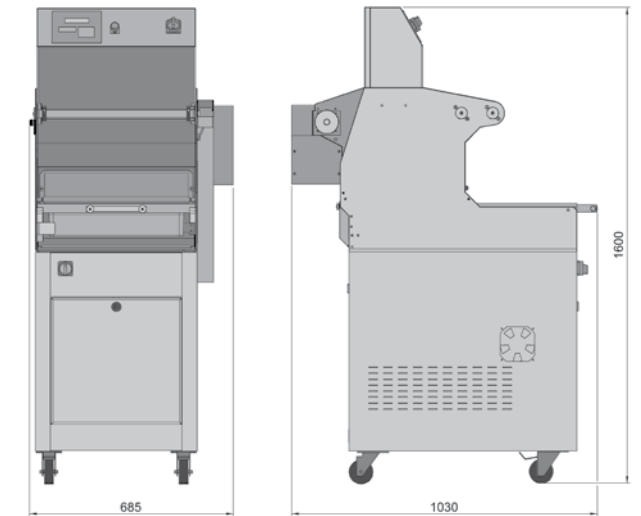

OPCIONES / OPCIONAIS

- Cámara de vacío con 150 mm de altura /
Camara de vacuo com 150mm de altura
- Fotocélula para film impreso /
Fotocelula para filme impresso
(sólo / apenas - ReeTray 25 VGM DIGIT)
- Carro abierto con ruedas (sólo para bomba de
20m³/h) /
Carro aberto com rodas (somente para bomba de
20m³/h)
- Dispositivo de molde inferior de elevación (altura
de la cámara de vacío) /
Dispositivo do molde inferior de elevação (altura
da câmara de vácuo)
- Filtro de líquido /
Filtro de liquido
- Filtro de aire /
Filtro de ar
- Silenciador de aire comprimido /
Silenciador de ar comprimido

Otras opciones a solicitud
Outros opcionais sob consulta

Número y dimensiones máximo por ciclo.
Numero e dimensoes maximo por ciclo.

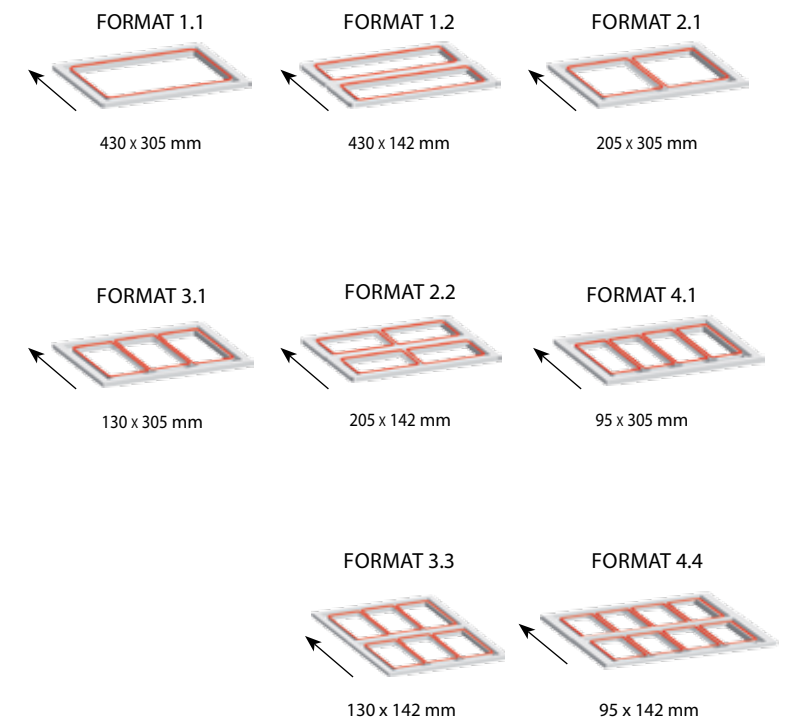

Se reserva la facultad de aportar modificaciones a los datos expuestos sin ningún aviso previo. /
As especificações estão sujeitas a alterações sem aviso prévio.

©Copyright by Reepack s.r.l. - RE-PTL-R1725-Rev/001-0113



Reepack S.r.l.
I - 24068 Seriate, Bergamo
reepack-it@reepack.com

Reepack Verpackungsmaschinen GmbH
D - 76297 Stutensee
reepack-de@reepack.com

Reepack Packaging Machinery S.L.
ES - 08027 Barcelona
reepack-es@reepack.com

Reepack Brasil Ltda
BR - CEP 04717-004 São Paulo
reepack-br@reepack.com

www.reepack.com

ReeTray 25 VGT-VGM

Semiautomatic Tray Sealer Machine



- Molde de Sellado
- Molde de Selagem



- Bobinado del borde
- Bobinado do retalho

- Panel de control
- Painel de controle



- Bandeja para molde

ReeTray 25 VGT



ReeTray 25 VGM
SISTEMA SKIN PACK A SOLICITUD



- Compresor de aire silencioso y bomba de vacío
- Compresor de ar silencioso e bomba de vacuo



h MAX 270 mm



ReeTray 25 VGM PAIL



ReeTray 25 FGT



DATOS TECNICOS	DADOS TECNICOS	ONLY FOR SEALING (S)		VACUUM + GAS (VG)	
		ReeTray 25 SXT	ReeTray 25 SXM	ReeTray 25 VGM	ReeTray 25 FGT
Dimensiones generales	Dimensões totais	685 x 1030 x h 740 mm	685 x 1030 x h 1490 mm	685 x 1030 x h 1600 mm	685 x 1030 x h 1600 mm
Peso incluido bomba	Peso incluido bomba	100 Kg - 170 Kg	125 Kg - 215 Kg	Ca. 215 Kg	100 - 215 Kg
Dimensiones max de la bandeja	Dimensões max da bandeja	430 x 305 mm	430 x 305 mm	430 x 305 mm	430 x 305 mm
Altura maxima da la bandeja	Altura maxima da bandeja	95 (150) mm	95 (150) mm	95 (150) mm	150 mm
Ancho max del film de sellado	Largura max do filme de selagem	470 mm	470 mm	470 mm	470 mm
Diámetro máximo de la bobina	Diámetro max da bobina	300 mm	300 mm	300 mm	300 mm
Diámetro máximo del tubo	Diámetro max do tubete	70 - 76 mm	70 - 76 mm	70 - 76 mm	70 - 76mm
Bomba de vacío	Bomba de vacuo			40 - 60 m ³ /h	No pump
Energía Eléctrica	Alimentação eletrica	1 / N / PE 230V AC - 50Hz*	3 / N / PE 400V AC - 50Hz*	3 / N / PE 400V AC - 50Hz*	1 / N / PE / 230V AC 50 Hz*
Consumo eléctrico	Consumo eletrico	Max 4,2 KW	Max 4,9 KW	Max 4,9 KW	Max 4,2 KW
Aire comprimido	Ar comprimido	6 bar - 7NI / c	6 bar - 7NI / c	6 bar - 7NI / c	6 bar - 7NI / c
Ciclos por minuto	Ciclos por minuto	2 - 6 ciclos / min.*	2 - 6 ciclos / min.*	2 - 6 ciclos / min.*	2 - 6 ciclos / min.*

*Diferentes formatos de energía bajo consulta / Diferentes formatos de energia sob consulta.

ReeTray 25 VG Modelo Reetray 25 VG Vacío y Gas / Modelo Reetray 25 VG Vacuo e Gas

ReeTray 25 SX Modelo Reetray 25 SX Sellado simple / Modelo Reetray 25 SX Selagem simples